

DANIEL COMPANY

1939 West 11th Street, Ste. E
Upland, CA 91786

Phone: (909) 982-1555
Fax: (909) 982-1855
danmech@sbcglobal.net
www.danielmechanical.com

DanFLEX HEAVY DUTY FLEXIBLE CONNECTOR/EXPANSION JOINT

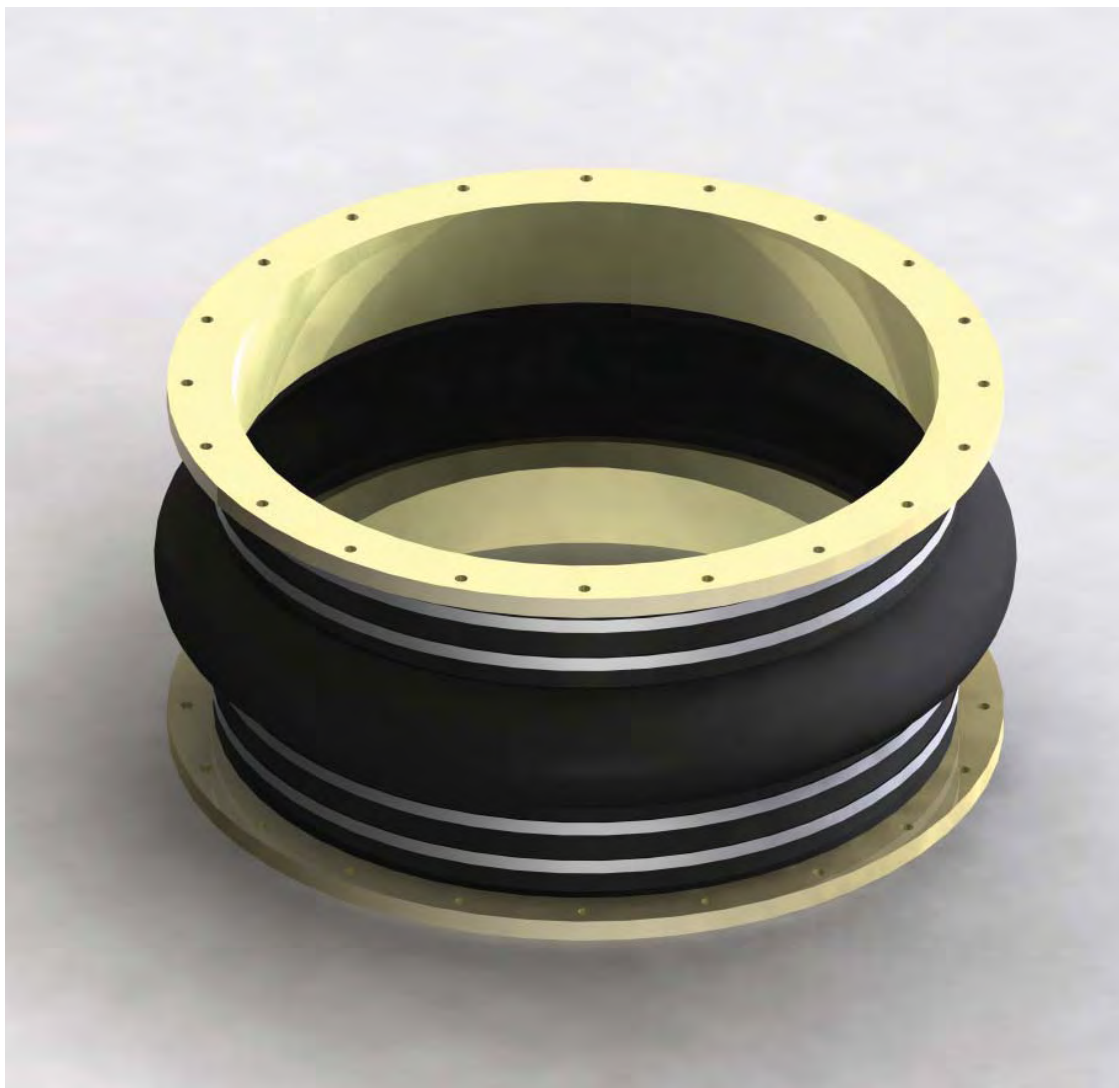

Made of High Quality Construction

DanFLEX is constructed of vulcanized layers of polyester tire-cord fabric reinforcement, sandwiched between a 60 to 70 durometer elastomeric inner liner and exterior cover. Tire-cord fabric is layered at an optimal bias angle with Resorcinol Formaldehyde Latex for superior rubber-to-fabric bonding. The elastomer is built as one continuous piece with an integrally molded, hollow-arched volute. 316 stainless steel retainer bands are used with adjustable screw seal type fasteners.

DanFLEX is suitable for use in H₂S-laden, corrosive environments, and is resistant to ultra violet rays.

Features Superior Flexibility

DanFLEX flexible connectors provide superior absorption of lateral, torsional, angular, and axial movement experienced in rigid ducting/piping systems due to thermal expansion and contraction, installation misalignment, and vibration.

Eliminates High Stress Points

The weakest point of a traditional flexible connector design is located annularly – where the back of the integrally molded elastomer flange meets the tubular section. *DanFLEX* relieves this high stress area by overlapping the tubular elastomer onto the hubs of the FRP flanges.

Infinite Bolt Hole Alignment Capability

DanFLEX flexible connector is designed to allow for infinite adjustment capability to accommodate any degree of axial misalignment of bolt holes.

Simpler and Easier to Replace

The elastomer portion of the *DanFLEX* flexible connector is an off-the-shelf commodity item. All parts of *DanFLEX* are pre-engineered, made to standard sizes, and are interchangeable. As a result, replacement lead time is reduced. Furthermore, in the event that the mating equipment is modified and requires a different bolt-hole pattern, the flange can easily be replaced without having to change out the entire flexible connector.

Withstands Extreme Torsional Forces

DanFLEX flexible connector is designed to absorb extreme and sudden torsional forces without wrinkling and (eventually) cracking of the molded elastomer volute. As an intended fail-safe feature, if excessive twisting forces are applied to the flex connector, the flanges will slip inside the tubular elastomer sleeve instead of tearing it.

Facilitates Accurate Installation

DanFLEX has an adjustable overall length, facilitating a more accurate fit and finish when installing in parent duct/pipe spools which have finite length measurements. This is easily achieved by extending the length of either of the FRP flanged stubs located at each end of the flexible connector.

Longer Warranty Period

Daniel Company's *DanFLEX* flexible connector comes with double the warranty period offered by other manufacturers.

DanFLEX STANDARD DESIGN AND CONSTRUCTION

FLEXIBLE SLEEVE — Single volute elastomer impregnated fabric or tire-cord

ELASTOMER MATERIAL — Neoprene, EPDM, or Hypalon

DUROMETER — 60 to 70 shore

ELASTOMER PRESSURE RATING — 5 psi

FLANGE — NBS PS 15-69-3.4.7

BAND — 316 stainless steel (SST) with screw seal fasteners

MAXIMUM TEMPERATURE RATING — 225°F

EXPANSION AND CONTRACTION — Up to a total of 4 inches

OPTIONAL ACCESSORIES — 316 SST control rod assemblies; custom flange bolt-hole patterns and ratings

DanFLEX ROUND FLEXIBLE CONNECTOR DETAIL DRAWING

NOTES:

1. ALL CONTROL RODS, NUTS, BOLTS & WASHERS ARE MADE OF 316 SST.
2. FLANGE BOLT-HOLE PATTERNS ARE PER NBS PS 15-69 TABLE II 3/4" THICK OR TO MATCH MATING FRP DUCTWORK.
3. CONTROL RODS AND RELATED ACCESSORIES ARE OPTIONAL.

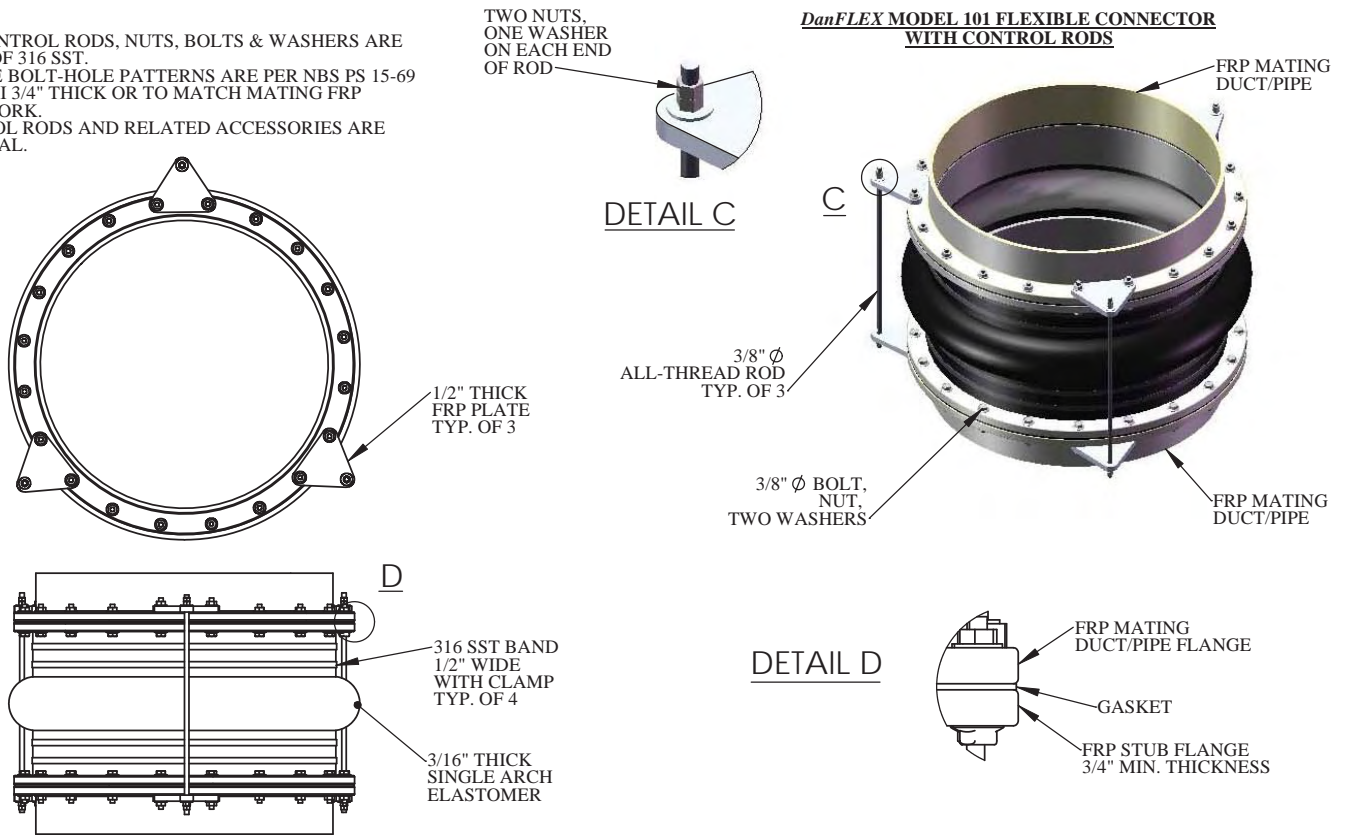

DanFLEX ROUND FLEXIBLE CONNECTOR DIMENSIONS

| SIZE (I.D.) | FLANGE THICKNESS (MIN.) | FLANGE O.D. | BOLT CIRCLE DIA. | BOLT HOLE DIA. | # OF BOLT HOLES | FLANGED FLEX CONNECTOR LENGTH (NOM.) |
|-------------|-------------------------|-------------|------------------|----------------|-----------------|--------------------------------------|
| 4" | 3/4" | 8 3/8" | 7" | 7/16" | 4 | 12" |
| 6" | 3/4" | 10 3/8" | 9" | 7/16" | 8 | 12" |
| 8" | 3/4" | 12 3/8" | 11" | 7/16" | 8 | 12" |
| 10" | 3/4" | 14 3/8" | 13" | 7/16" | 12 | 12" |
| 12" | 3/4" | 16 3/8" | 15" | 7/16" | 12 | 12" |
| 14" | 3/4" | 18 3/8" | 17" | 7/16" | 12 | 12" |
| 16" | 3/4" | 20 3/8" | 19" | 7/16" | 16 | 12" |
| 18" | 3/4" | 22 3/8" | 21" | 7/16" | 16 | 12" |
| 20" | 3/4" | 24 3/8" | 23" | 7/16" | 20 | 12" |
| 24" | 3/4" | 28 3/8" | 27" | 7/16" | 20 | 12" |
| 30" | 3/4" | 34 3/8" | 33" | 7/16" | 28 | 12" |
| 36" | 3/4" | 40 3/8" | 39" | 7/16" | 32 | 18" |
| 42" | 3/4" | 46 3/8" | 45" | 7/16" | 36 | 18" |
| 48" | 3/4" | 54 3/8" | 52" | 9/16" | 44 | 18" |
| 54" | 3/4" | 60 3/8" | 58" | 9/16" | 44 | 18" |
| 60" | 3/4" | 66 3/8" | 64" | 9/16" | 52 | 18" |
| 72" | 3/4" | 79" | 76" | 9/16" | 64 | 18" |

DanFLEX SUGGESTED SPECIFICATIONS FOR ROUND FLEXIBLE CONNECTORS

Flexible connectors shall be provided wherever indicated. To maintain overall system responsibility by a singular source, all flexible connections shall be supplied by the MANUFACTURER of the FRP duct/pipe. Acceptable flexible connector is ***DanFLEX*** Model 101 as manufactured by Daniel Company, or equal.

Flexible connectors are intended to be used in rigid duct/pipe systems for lateral, torsional, angular and axial movement due to expansion, contraction, and vibration. Product may be utilized to compensate for minimal misalignment.

Construction shall be of multiple layers (2 minimum) of vulcanized polyester tire-cord fabric reinforcement, sandwiched between 60 to 70 durometer elastomer inner liner and exterior cover. Use of reprocessed/reclaimed rubber is not acceptable. Tire-cord fabric will be layered at an optimal bias angle with Resorcinol Formaldehyde Latex for superior rubber-to-fabric bonding.

Seamless construction, built as one continuous piece with integral molded hollow arched volutes, shall permit up to a total of 4" of axial contraction and expansion.

Flexible connectors shall be designed to allow for a minimum of 1" of offset movement in any direction. No wrap, seamed or spliced type flexible connectors will be allowed

Flanges shall be of FRP construction per NBS PS 15-69-3.4.7. Bolt-hole pattern shall fit that of mating duct/pipe or equipment.

316 SST retainer bands shall be used with adjustable screw seal type fasteners. All hardware and materials of construction shall be suitable for H₂S laden corrosive environment and able to resist UV rays.

Approved manufacturer of flexible connectors shall be:

1. Daniel Company – ***DanFLEX*** Model 101



DANIEL COMPANY Fiberglass Air Pollution Control Systems

Corporate Office
1939 West 11th Street, Ste E • Upland, CA 91786
Ph: (909) 982-1555 • Fax: (909) 982-1855

Manufacturing Facility
9972 Rancho Road • Adelanto, CA 92301
Ph: (760) 246-1100 • Fax: (760) 246-1161

Website: www.danielmechanical.com

Email: Danmech@sbcglobal.net